



Orion Engineered Seals

"It's not only what we **make...**it's what we **know!**"

Phone: 513-765-8100 Fax: 513-765-8111
E-mail: sales@orionseals.com

PSD Application Data Sheet

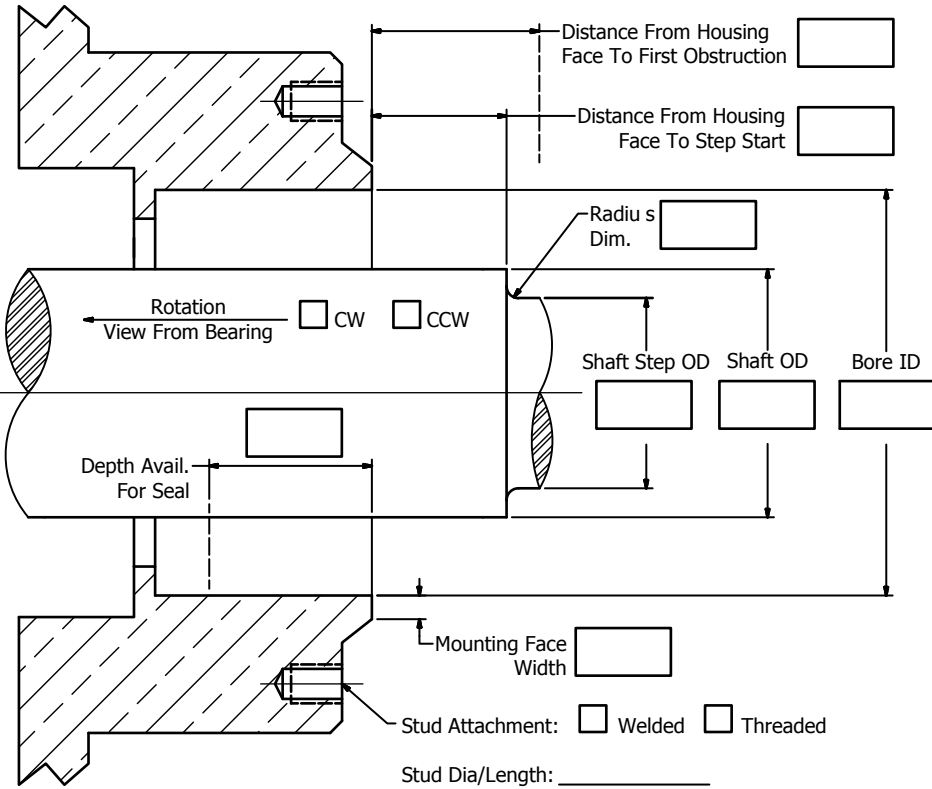

Company Name: _____

Location: _____

Contact Name: _____

Phone Number: _____

E-mail: _____

Equipment Make/Model: _____

RPM: _____

Shaft Orientation: _____

Shaft Axial Movement: _____

Shaft TIR: _____

Shaft/Bore TIR: _____

Temperature: _____ °F _____ °C

Product: _____

Head Pressure At Seal Location: _____

System Vented: Yes No

Seal Air Allowed In Process: Yes No

Flange Bolt Pattern:

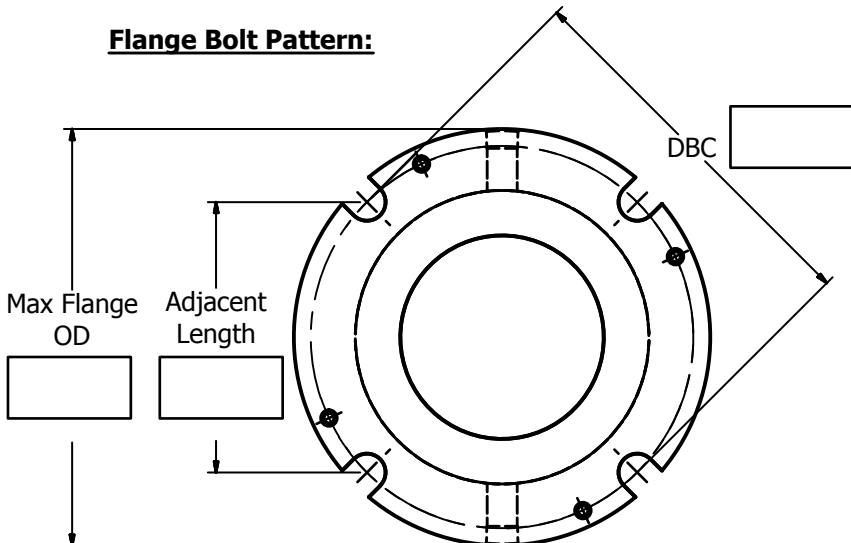

Seal Requirements

Split Non-split

Material Of Const: Bronze S.S. Other: _____

O-ring Material: Viton Other: _____

Additional Application Information: