



Orion Engineered Seals

"It's not only what we **make**...it's what we **know**!"

Phone: 513-765-8100 Fax: 513-765-8111
E-mail: sales@orionseals.com

BPD Application Data Sheet

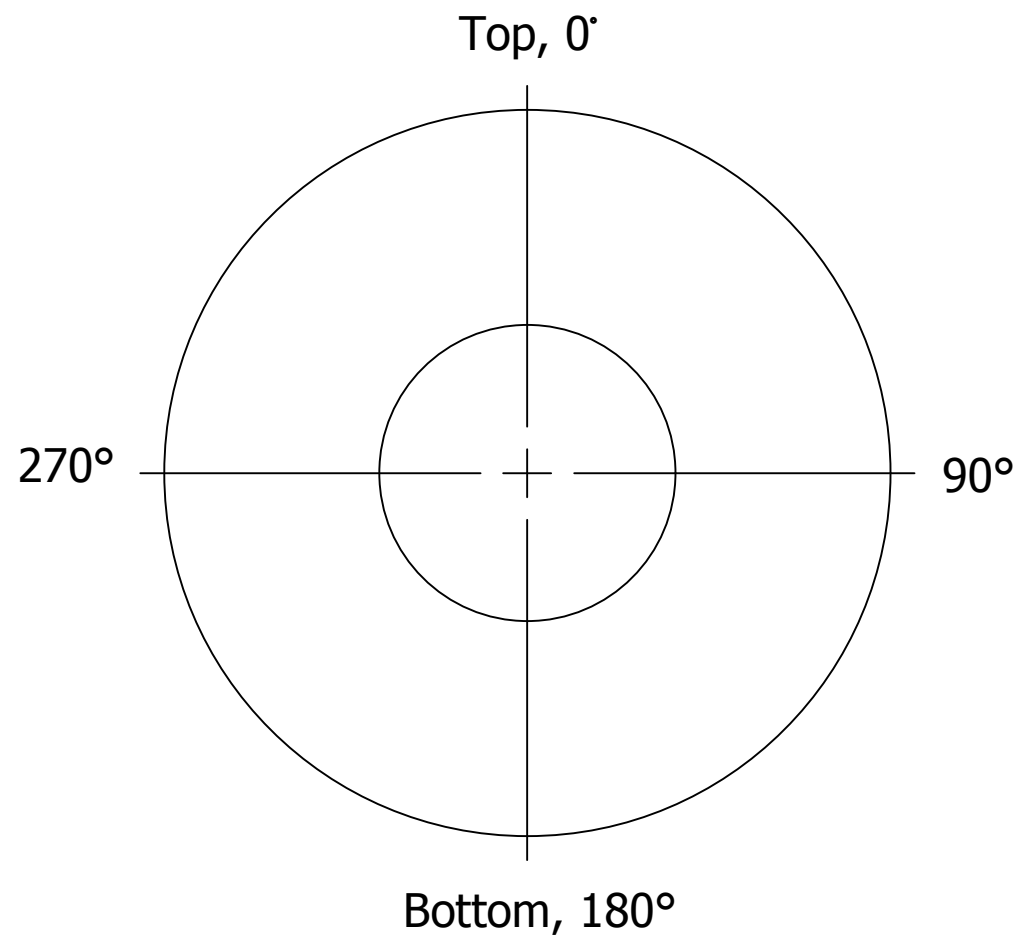
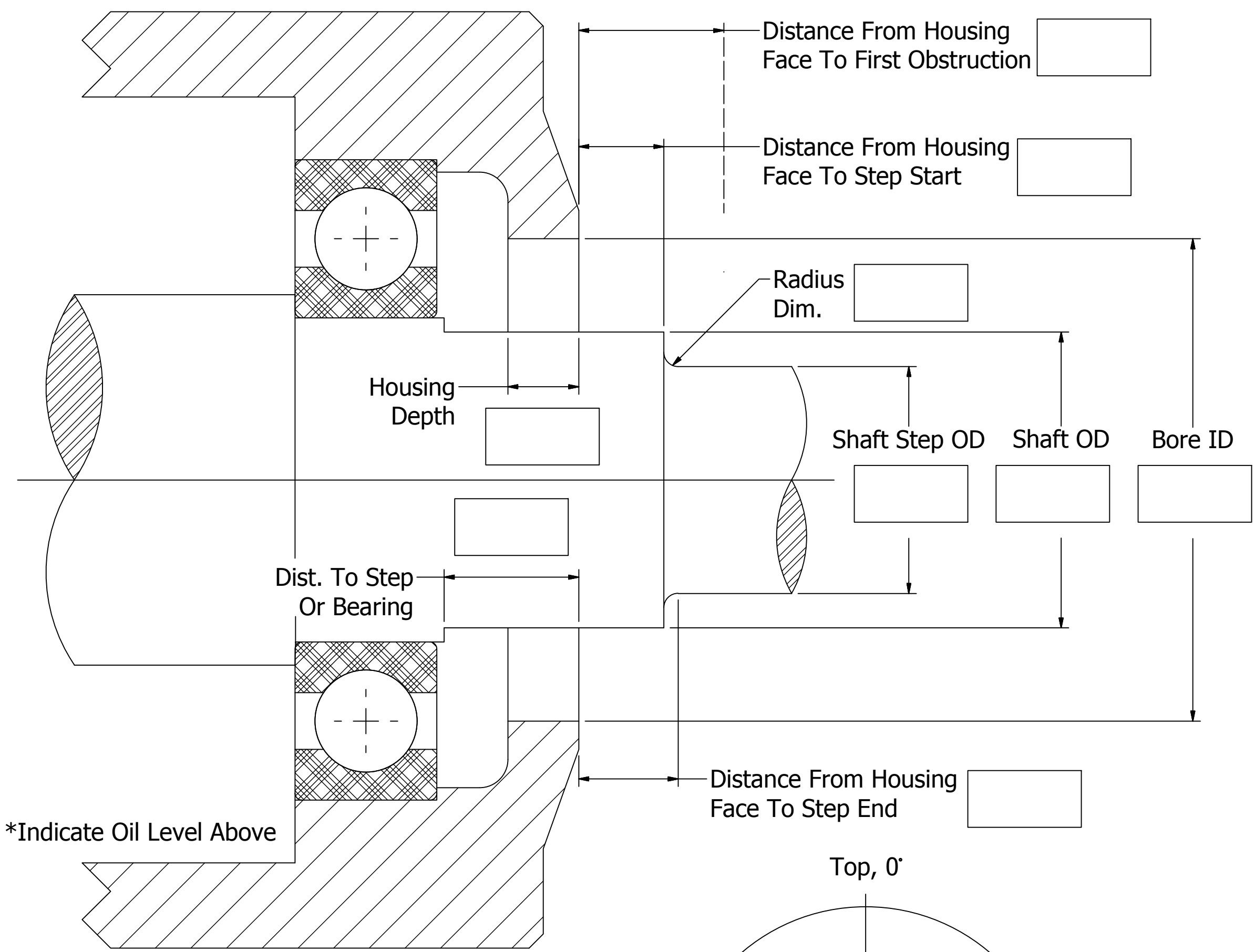

Company Name: _____
Location: _____

Contact Name: _____
Phone Number: _____
E-mail: _____

Application: Pump Motor Gearbox Other: _____

Equipment Make/Model: _____

Operating Environment: _____

RPM: _____

Shaft Orientation: Horizontal Vertical

Shaft Axial Movement: _____

Shaft TIR: _____

Shaft/Bore TIR: _____

Temperature: _____ °F/°C

Lubrication: Oil* Grease Oil Mist Circulating

Bearing Housing: Solid Split

Seal Requirements

Press-fit Flange Mount**

Solid Split

Material Of Const: Bronze S.S. Other: _____

O-ring Material: Viton Other: _____

Additional Application Information:

** Number Of Bolts: _____

Bolt Size: _____

DBC: _____

Max Flange Dia: _____